



The stripline kicker has four electrodes with the length of 30 cm and the opening angle of  $60^\circ$  rotated  $45^\circ$  from horizontal plane. As it was impossible to prepare amplifiers which have bandwidth from 95 kHz to 255 MHz, we divided the bandwidth into two parts; from 95 kHz to 25 MHz (lower-band) and from 20 MHz to 255 MHz (higher-band) and used two stripline kickers for each amplifier sets. Totally, four lower-band amplifiers and four higher-band amplifiers were used. The maximum power output for each amplifiers was 200 W.

The damping times for the bunch current of 4 mA are estimated about  $400 \mu\text{s}$  for the horizontal plane and about  $800 \mu\text{s}$  for the vertical plane.

## 2.2 Longitudinal system

Figure 2 shows a block diagram of the longitudinal feedback system prototype. The longitudinal position of a

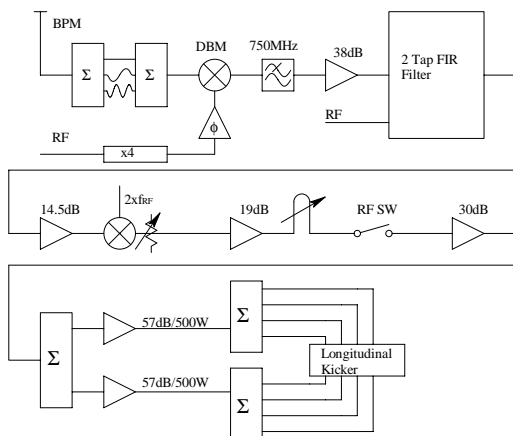

Figure 2: Block diagram of the longitudinal feedback system prototype installed in AR.

bunch is measured with a wideband phase detection system. Using same BPF and the DBM as the transverse system, the sine-like burst signal from a bunch is multiplied by the quadruple of the RF signal. This time the nominal phase is adjusted to be  $90^\circ$  shifted from that of the bunch. By rejecting the higher-frequency component with the LPF, baseband signal of a synchrotron oscillation is detected as the form of  $\sim I_b \Phi \sin(\omega_s t)$  if the amplitude  $\Phi$  is small.

The signal process is performed with a two-tap FIR filter realized by a simple hardware system. Detailed description of the filter system is written in the reference[1]. We have used a four cells of series-drift-tube type longitudinal kicker just same structure as used in ALS at LBNL[2]. Total shunt impedance was about  $1.6 \text{ k}\Omega$  and the maximum feedback voltage was  $1.7 \text{ kV/turn}$ .

## 3 BEAM TEST OF THE FEEDBACK SYSTEMS

General information of the high beam current study of AR is written elsewhere[3]. We therefore concentrate only the subject concerning to the feedback experiments here.

### 3.1 Transverse feedback experiment

We have encountered heavy coupled bunch instabilities both in horizontal and longitudinal planes and could not accumulate bunch train without the transverse feedback systems. Maximum number of stored bunches was less than 25 bunches.

With the transverse feedback system on, we successfully accumulated more than 300 bunches with the bunch spacing of 2 ns and the bunch current of 1 mA. Table 2 shows the maximum number of accumulated bunches on the bunch train mode with the bunch spacing of 2 ns together with the state of each feedback system. The maxi-

Bunch current	H: off V: off	H: On V: off	H: off V: On	H: On V: On
1 mA	18	20	—	> 300
2 mA	20	70	20	> 170
4 mA	25	25	65	> 100

Table 2: Maximum number of stored bunches with the bunch train mode. H means horizontal system and V means vertical system.

imum stored beam current of 376 mA with the transverse feedback system on was achieved with the bunch train mode of 4 mA per bunches. We also applied the feedback system to the equally filled mode such as 8 ns or 10 ns spacing mode and succeeded to suppress the instabilities.

We have measured the growth and damp of the instabilities in time domain employing the memory function of the two-tap FIR filter complex. As the filter has 1 Mb of memory, we have recorded the oscillation of all the bunches about 1600 turns. The growth time of the instabilities just after turning off the feedback system was about  $2 \sim 3 \text{ ms}$  for both horizontal and vertical planes, much faster than the radiation damping time. The damping time just after turning on the feedback was less than 1 ms for horizontal plane, about 2 ms for vertical plane, which are consistent with the rough estimates of the damping times. By arranging the data in a two dimensional array of bunch number vs. revolution time and making the Fourier transform of each rows, we get the change of the modes of the oscillation of the bunches in time domain. Figure 3 shows an example of the growing modes of vertical instabilities starting 3 ms after turning off the vertical feedback system. The filling pattern was equally spaced mode with 5 bunch spacing, 2 mA/bunch. Clearly only one mode corresponding to 10.2 MHz is growing rapidly. In the horizontal plane, three modes corresponding to 9.4 MHz, 22.2 MHz and 25 MHz were growing rapidly.

### 3.2 Longitudinal feedback experiment

As it was impossible to accumulate the multi-bunched beam without transverse feedback system, we always turned on the transverse systems with the maximum gain during the longitudinal experiments. We have at first tuned

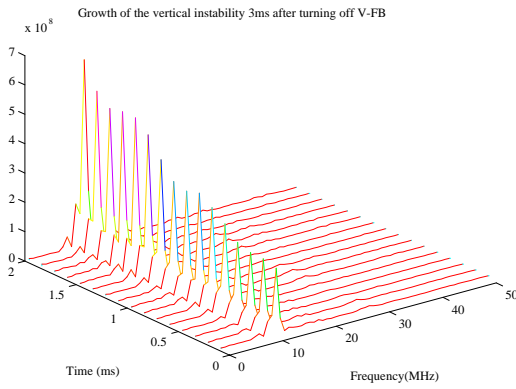

Figure 3: Growth of the vertical coupled bunch oscillation observed with the two-tap FIR filter.

the tap positions of the two tap filter to have the maximum gain with the positive feedback loop. Also the phase of the kicker was adjusted with the same situations.

In the bunch train mode with the bunch spacing of 4 ns and the bunch current of 2 mA, the synchrotron oscillation was successfully damped up to 6 bunches. However, when we injected the 7-th bunch, it occurred strong quadrupole oscillation in the 7-th bunch and was impossible to damp, though the first sideband was suppressed. It obviously shows there is huge longitudinal impedance in the ring.

In the equally spaced bunched mode with 10 bunches space and 2 mA/bunch, we successfully suppressed the longitudinal oscillation. However, if we once turned off the feedback system, we could not re-capture the oscillation when turning on the feedback until the total current has reduced from 120 mA to 90 mA. This shows that the maximum feedback voltage was insufficient. With the equally spaced mode with 5 bunch space and 1 mA/bunch, we also successfully suppressed the oscillation. This time we easily re-captured the oscillation after turning off the feedback system. Figure 4 shows the beam spectrum with the longitudinal feedback off and on.

During the high-current study at AR, we monitored the temperatures of the vacuum components and the high power components of the feedback systems. No fatal troubles has occurred during the experiment. We also checked the status of the components after the experiment and got no damage at all except the final power combiner to the longitudinal kickers.

#### 4 SUMMARY

We have installed the transverse and longitudinal feedback systems which are prototypes for KEKB rings in the TRISTAN-AR and examined the feasibility with the high beam current study. As the instabilities were fairly stronger than expected before the experiment, it was unexpectedly heavy examination for our feedback systems.

The analog transverse feedback systems worked very well. With the two-tap FIR filter as the memory board, we observed the growth and damp of the modes of the os-

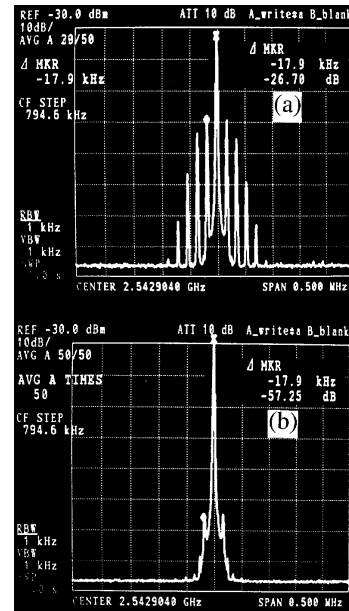

Figure 4: Beam spectrums (a) with longitudinal feedback off (b) with longitudinal feedback on. Without the feedback, there appeared many synchrotron sidebands corresponding to the strong longitudinal oscillations. The amplitude of the first sideband has reduced down to -30dB with the longitudinal feedback. The total beam current was about 120 mA.

cillation. Also our system worked as the instrumentation tool for other experiments, such as the first ion trapping experiment[4]. They clearly observed the individual oscillation of bunches in the bunch train with 2 ns spacing.

The longitudinal system worked, though it also showed the insufficient feedback voltage for the oscillation with large amplitude. Invest much more power in the final amplifier and the use of kickers with larger shunt impedance will be necessary for the KEKB rings.

#### 5 ACKNOWLEDGMENTS

The authors would like to express their sincere appreciation to Prof. T. Kasuga and Dr. T. Obina of KEK-PF for numerous thoughtful discussions. We thank Dr. Y. Funakoshi who spent much time to operate the accelerator during our experiments.

#### 6 REFERENCES

- [1] E. Kikutani, *et al*, in proceedings of the 5th European Particle Accelerator Conference, Sitges, Spain, 1996, p.1893.
- [2] J. N. Corlett *et al*, in proceedings of the 4th European Particle Accelerator Conference, London, UK, 1994 p. 1625.
- [3] Y. Funakoshi, these proceedings.
- [4] H. Fukuma, *et al*, these proceedings.